

ROTEL *hi-fi*

ROTEL *hi-fi*

ROTEL *hi-fi*

ROTEL *hi-fi*

ROTEL *hi-fi*

ROTEL *hi-fi*

ROTEL *hi-fi*

ROTEL *hi-fi*

ROTEL *hi-fi*

ROTEL *hi-fi*

ROTEL *hi-fi*

ROTEL *hi-fi*

ROTEL *hi-fi*

ROTEL *hi-fi*

ROTEL *hi-fi*

ROTEL *hi-fi*

ROTEL *hi-fi*

ROTEL *hi-fi*

ROTEL *hi-fi*

ROTEL *hi-fi*

RCC-955

CD MULTI-DISC CHANGER

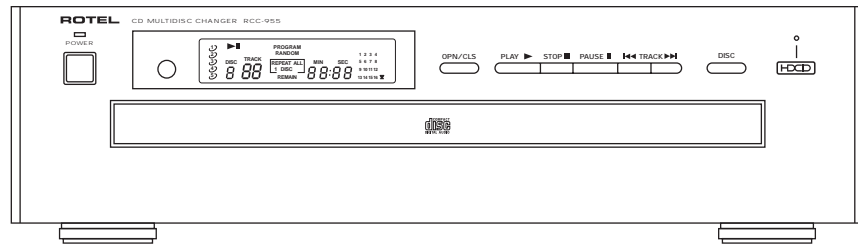

Owner's Manual

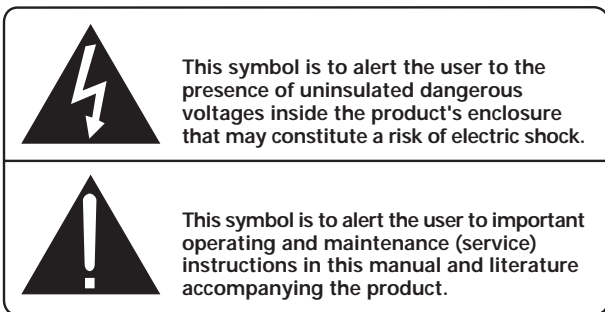
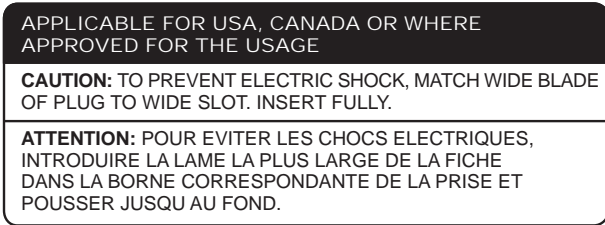

WARNING:
There are no user serviceable parts inside. Refer all servicing to qualified service personnel.

WARNING:
To reduce the risk of fire or electrical shock, do not expose the unit to moisture or water. Do not allow foreign objects to get into the enclosure. If the unit is exposed to moisture, or a foreign object gets into the enclosure, immediately disconnect the power cord from the wall. Take the unit to a qualified service person for inspection and necessary repairs.

Read all the instructions before connecting or operating the unit. Keep this manual so you can refer to these safety instructions.

Heed all warnings and safety information in these instructions and on the product itself. Follow all operating instructions.

Clean the unit only with a dry cloth or a vacuum cleaner.

Do not place the unit on a bed, sofa, rug, or similar surface that could block the ventilation slots. If the unit is placed in a bookcase or cabinet, there must be sufficient clearance around the unit and ventilation of the cabinet to allow proper cooling.

Keep the unit away from radiators, heat registers, stoves, or any other appliance that produces heat.

The unit must be connected to a power supply only of the type and voltage specified on the rear panel of the unit.

Connect the unit to the power outlet only with the supplied 2-pin polarized power supply cable or an exact equivalent. Do not modify the supplied cable in any way. Do not attempt to defeat grounding and/or polarization provisions. The cable should be connected to a 2-pin polarized wall outlet, matching the wide blade of the plug to the wide slot of the receptacle. Do not use extension cords.

Do not route the power cord where it will be crushed, pinched, bent at severe angles, exposed to heat, or damaged in any way. Pay particular attention to the power cord at the plug and where it exits the back of the unit.

The power cord should be unplugged from the wall outlet if the unit is to be left unused for a long period of time.

Immediately stop using the unit and have it inspected and/or serviced by a qualified service agency if:

- The power supply cord or plug has been damaged.
- Objects have fallen, or liquid has been spilled, into the unit.
- The unit has been exposed to rain.
- The unit shows signs of improper operation
- The unit has been dropped or damaged in any way

Place the unit on a fixed, level surface strong enough to support its weight. Do not place the unit on a moveable cart that could tip over.

NOTE: There are 2 screws that hold the disc drawer securely in place during shipment. **These screws must be removed before using the RCC-955.** See the Getting Started section for more information.



Figure 1: Front Panel Controls

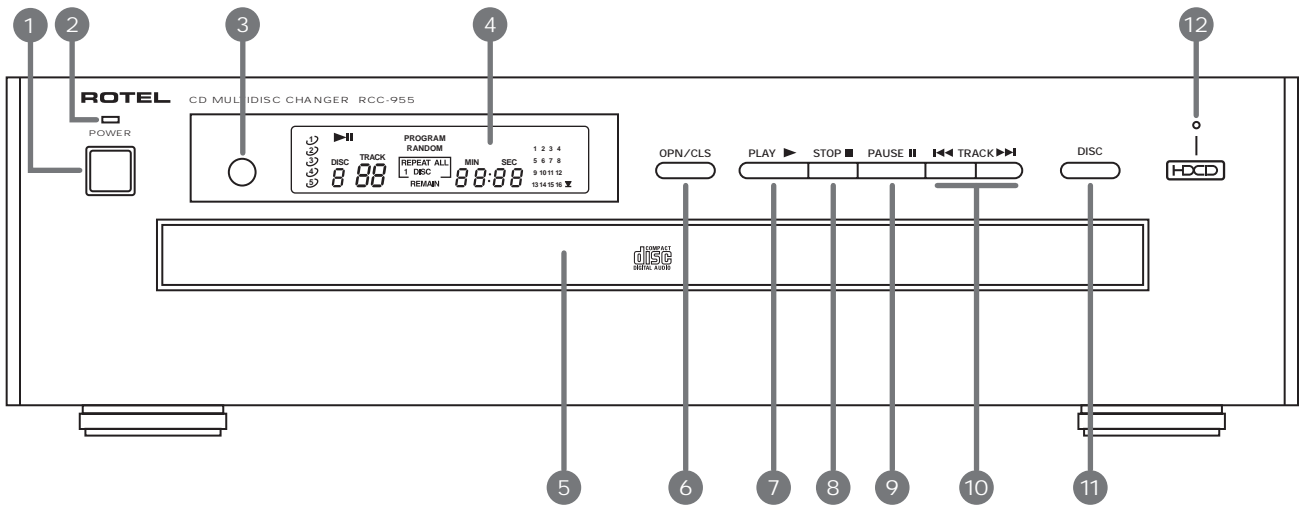

Figure 2: Rear Panel Connections

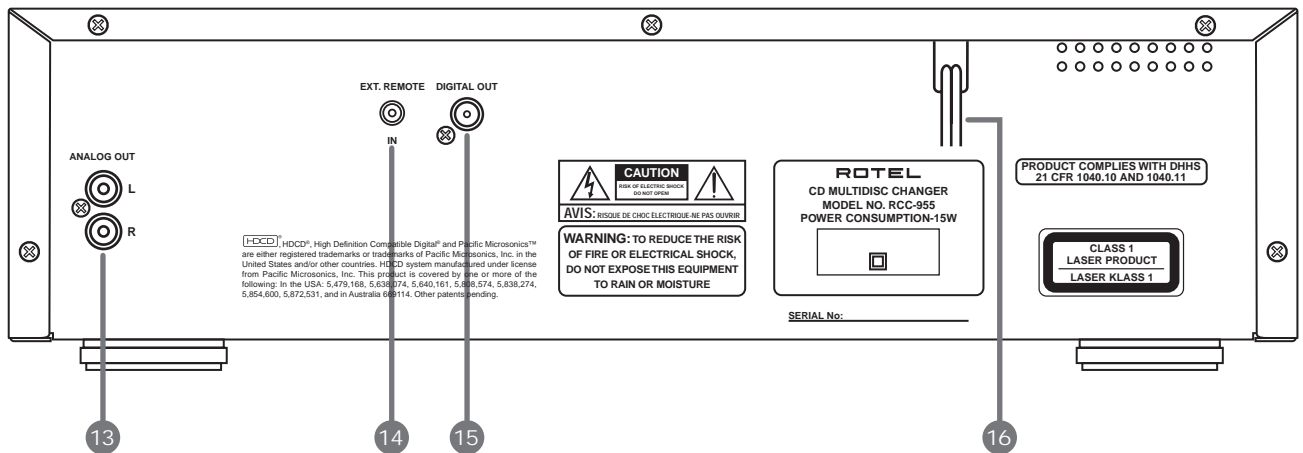

Figure 3: Display Panels 4

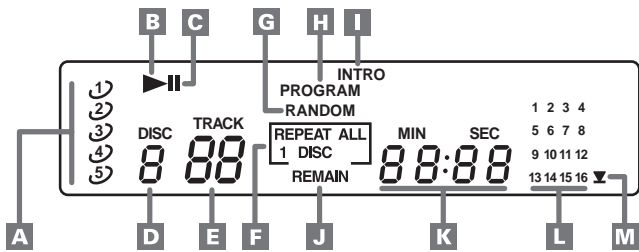

Figure 4: RR-D92 Remote Control

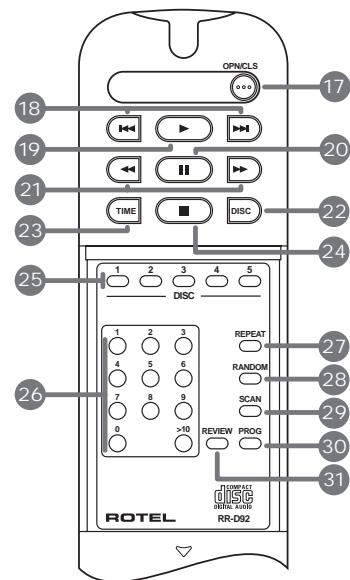

Figure 5: Audio Signal Connection

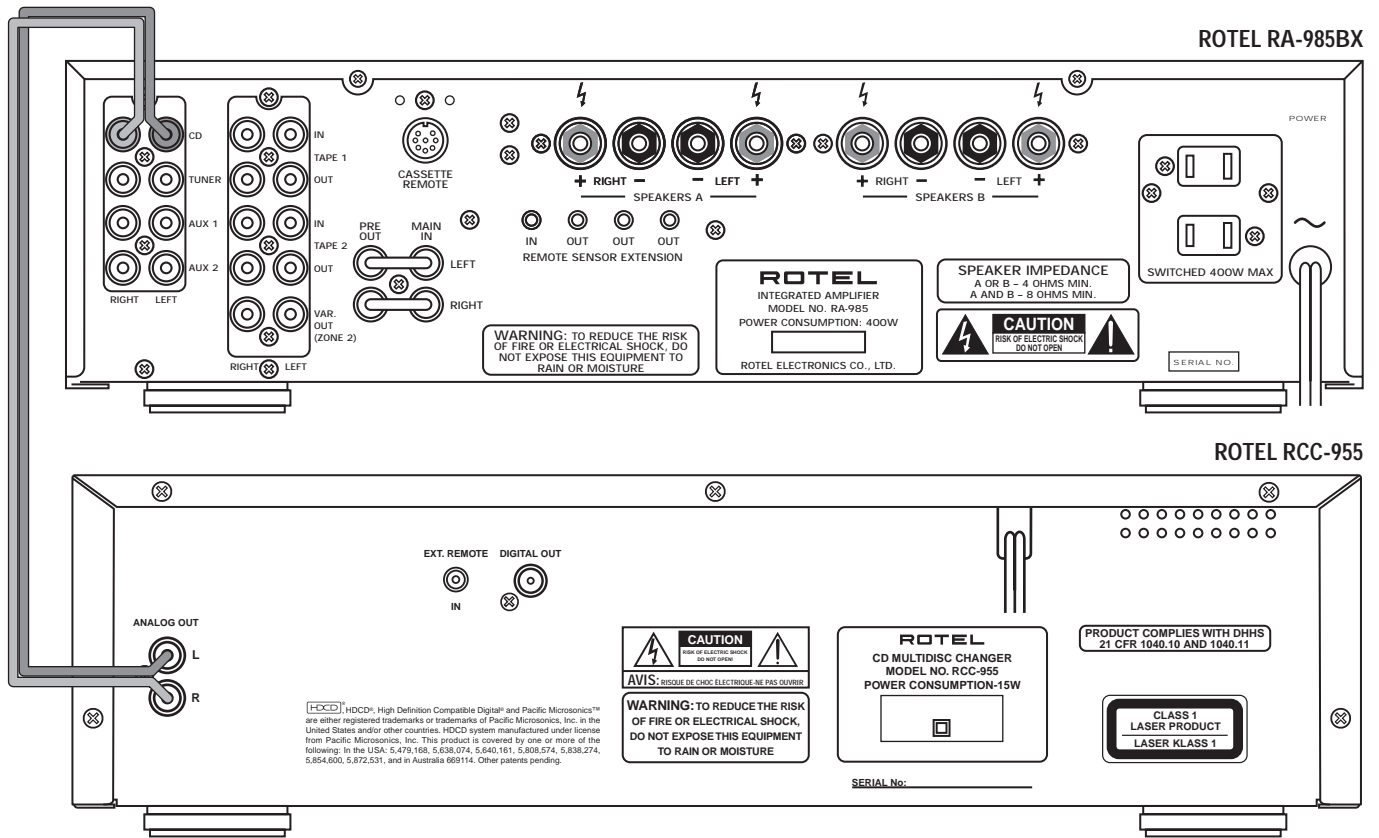
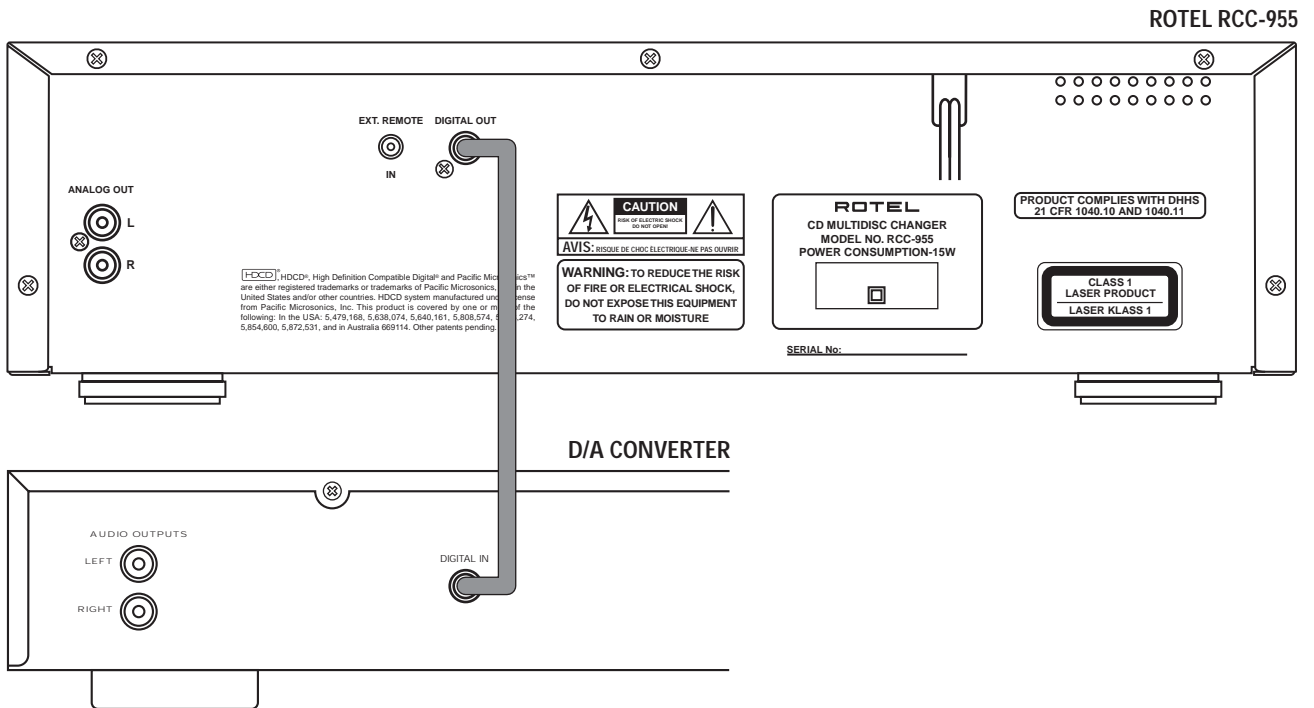

Figure 6: Digital Output Connection



Contents (circled numbers refer to illustration)

About Rotel _____	5
Getting Started _____	5
About HDCD® ¹²	
A Few Precautions	6
Placement	6
Cables	6
Handling Compact Discs _____	6
AC Power and Control _____	7
AC Power Input ¹⁶	7
Power Switch ¹ and Power Indicator ²	7
Output Connections _____	7
Analog Outputs ¹³	7
Digital Output ¹⁵	7
Remote Control _____	7
Remote Sensor ³	7
External Remote Input ¹⁴	8
Remote Control Batteries	8
Loading Discs _____	8
Disc Tray ⁵ and Open/Close Buttons ⁶ and ¹⁷	8
Disc Button ¹¹ and ²²	8
Selecting a Disc to Play _____	8
Disc 1-5 Buttons ²⁵ (remote only)	8
Playing Discs _____	8
Play Buttons ⁷ and ¹⁹	8
Pause Button ⁹ ²⁰	9
Stop Button ⁸ ²⁴	9
Track Skip Buttons ¹⁰ ¹⁸	9
Track Selection Buttons ²⁶ (remote only)	9
Search Buttons ²¹ (remote only)	9
Display Panel ⁴ and A - M _____	9
Time Button ²³ (remote only) _____	10
Each/Remain Mode	10
Total/Remain Mode	10
Repeat Play Button ²⁷ (remote only) _____	10
Repeat 1 Track	10
Repeat 1 Disc	10
Repeat All Discs	10
Random Play Button ²⁸ (remote only) _____	10
Intro Scan Button ²⁹ (remote only) _____	11
Programmed Disc Play _____	11
Program Button ³⁰	11
Track Programming	11
Adding Tracks to a Program	12
Review Button ³¹	12
Playing Programmed Tracks _____	12
Troubleshooting _____	13
Display Is Not Lit	13
Fuse Replacement	13
Disc Does Not Play	13
No Sound	13
Sound Skips	13
Hum	13
Specifications _____	13

About Rotel

A family whose passionate interest in music led them to manufacture high fidelity components of uncompromising quality founded Rotel over 30 years ago. Through the years that passion has remained undiminished and the family goal of providing exceptional value for audiophiles and music lovers, regardless of their budget, is shared by all Rotel employees.

The engineers work as a close team, listening to, and fine tuning each new product until it reaches their exacting musical standards. They are free to choose components from around the world in order to make that product the best they can. You are likely to find capacitors from the United Kingdom and Germany, semi conductors from Japan or the United States, while toroidal power transformers are manufactured in Rotel's own factory.

Rotel's reputation for excellence has been earned through hundreds of good reviews and awards from the most respected reviewers in the industry, who listen to music every day. Their comments keep the company true to its goal – the pursuit of equipment that is musical, reliable and affordable.

All of us at Rotel thank you for buying this product and hope it will bring you many hours of enjoyment.

Getting Started

Thank you for purchasing the Rotel RCC-955 CD Multi-Disc Changer. When used in a high-quality music audio system, it will provide years of musical enjoyment.

The RCC-955 is a full featured, high performance component. It is the ideal choice for those who want the convenience of a CD changer, but who will not accept compromised sound quality. The RCC-955 features high precision 8-times oversampling digital filters. In addition it incorporates HDCD circuitry. (See the following section.)

Ease of operation has not been forgotten. While one disc is playing you can change any of the other four. Full remote control, 32 track programming, and track scanning are provided.

The highest quality components, such as metal film resistors and polystyrene or polypropylene capacitors are used in important signal paths. All aspects of this design have been examined with the final goal being faithful reproduction of music.

The RCC-955 is easy to install and use. If you have experience with other stereo systems, you shouldn't find anything perplexing. Simply connect it to the associated components and enjoy.

HDCD®, HDCD®, High Definition Compatible Digital® and Pacific Microsonics™ are either registered trademarks or trademarks of Pacific Microsonics, Inc. in the United States and/or other countries. HDCD system manufactured under license from Pacific Microsonics, Inc. This product is covered by one or more of the following: In the USA: 5,479,168, 5,638,074, 5,640,161, 5,808,574, 5,838,274, 5,854,600, 5,872,531, and in Australia 669114. Other patents pending.

About HDCD® 12

HDCD discs are encoded with a high density data stream. During playback this high density data stream is decoded to a conventional digital signal. This HDCD encode/decode system greatly reduces the errors that are normally generated during the analog-to-digital, and then digital-to-analog, conversions. The HDCD system is automatically activated, and the HDCD Indicator 12 lights, whenever an HDCD disc is played.

A Few Precautions

Please read this manual carefully. It provides information on how to incorporate the RCC-955 into your system as well as information that will help you get optimum sound performance. Please contact your authorized Rotel dealer for answers to any questions you might have. In addition, all of us at Rotel welcome your questions and comments.

NOTE: There are 2 screws that hold the disc drawer securely in place during shipment. The screws have red plastic handles that make them easy to identify and remove. Gently turn the RCC-955 on its side and turn the screws counterclockwise to remove them. If the screws are not removed the disc drawer will not open.

If you neglected to remove the screws before attempting to use the RCC-955, turn the unit off and unplug it from the wall outlet. Then remove the screws as described above.

Keep the screws in a safe place because they must be replaced when the RCC-955 is moved. Before the RCC-955 is moved, remove all the CDs from the disc tray and close the disc drawer. Wait until the display shows "0 00 00:0" then turn off the power switch and unplug the power cord from the wall outlet. Turn the unit on its side and reinstall the screws.

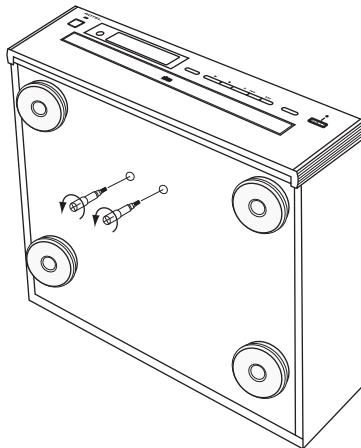

Save the RCC-955 shipping carton and all enclosed packing material for future use. Shipping or moving the RCC-955 in anything other than the original packing material may result in severe damage to your amplifier.

The RCC-955 is designed to play compact discs bearing the identification logo shown here. Other types of disc must not be used.



Before moving the RCC-955, remove all discs from the unit. This will prevent possible damage should the discs shift out of their normal positions inside the unit.

Keep the disc tray closed except when loading or unloading discs. This helps keep dust away from the sensitive laser pick up.

Fill out and send in the owner's registration card packed with the RCC-955. Also be sure to keep the original sales receipt. It is your best record of the date of purchase, which you will need in the event warranty service is ever required.

Placement

Like all audio components that handle low-level signals, the RCC-955 can be affected by its environment. To minimize the chance the RCC-955 will pick up hum or interference, do not place it on top of an amplifier or any other device that has a large power transformer. Keep the RCC-955 away from devices that have motors for the same reason. Do not place the RCC-955 where it will be exposed to direct sunlight. Finally do not use the RCC-955 where the temperature will be above 95°F/35°C or below 41°F/5°C. If the RCC-955 is moved from a cold environment to a warm one, condensation can form on the optical components, which will prevent proper operation. Do not use the RCC-955 for at least 30 minutes after it is moved from a cold environment.

We recommend installing the RCC-955 in furniture designed to house audio components. Such furniture is designed to reduce or suppress vibration which can adversely affect sound quality. Ask your authorized Rotel dealer for advice about component furniture and proper installation of audio components.

Cables

Be sure to keep the power cords, digital signal cables and regular audio signal cables in your installation away from each other. This will minimize the chance of the regular audio signal cables picking up noise or interference from the power cords or digital cables. Using only high quality, shielded cables will also help to prevent noise or interference from degrading the sound quality of your system. If you have any questions see your authorized Rotel dealer for advice about the best cable to use with your system.

Handling Compact Discs

Handle CDs carefully. Hold them by their edges, as shown here, and avoid touching the playing surface.



Fingerprints and dust should be carefully wiped off the disc's signal surface (glossy surface) with a soft cloth. Wipe in a straight motion from the inside to the outside of the disc.

Never use chemicals, such as record cleaning sprays, anti-static sprays or fluids, benzene or thinner to clean compact discs. These chemicals will damage the disc's plastic surface.

Keep discs in their storage cases when not in use to protect them from dust and scratches. Do not expose compact discs to direct sunlight, high humidity or high temperatures for extended periods of time.

AC Power and Control

AC Power Input 16

Your RCC-955 is configured at the factory for the proper AC voltage in the country where you purchased it (either 115 volts or 230/240 volts). The AC line configuration is noted on a decal on the back panel.

Note: Should you move your CD player to another country, it may be possible to re-configure it for use on a different line voltage. Do not attempt to perform this conversion yourself. Opening the enclosure of the RCC-955 exposes you to dangerous voltages. Consult a qualified service person or the Rotel factory service department for information.

The RCC-955 should be plugged directly into a 2-pin polarized wall outlet or into the switched outlet on another component in your audio system. Do not use an extension cord.

Be sure the power switch on the front panel of the RCC-955 is turned off (in the "out" position). Then plug the power cord into an AC power outlet.

If you are going to be away from home for an extended period of time such as a month-long vacation, it is a sensible precaution to unplug your CD player (as well as other audio and video components) while you are away.

Power Switch 1 and Power Indicator 2

The Power Switch is located on the left side of the front panel. Push the switch button in to turn on the RCC-955. To turn the RCC-955 off, push the button again to return it to the "out" position.

Note: If you are using a switched outlet to turn on and off your CD player, you should leave the power switch in the "on" position. When AC power is applied to the unit, it will power up in fully active mode.

When the Power Switch is turned on the disc in position 1 in the tray is selected. The Disc and Track Displays illuminate and show Disc 1/ Track 1. The Time Indicator also illuminates.

Output Connections

The RCC-955 gives you a choice of analog or digital output signals. The analog output signal from the built-in Digital to Analog converter is used with conventional analog audio components. The digital output, which provides an unprocessed digital data signal, is used with outboard D/A converters or digital processors.

Note: To prevent loud noises that neither you nor your speakers will appreciate, make sure all the system components are turned off when you make any signal connections.

Analog Outputs 13

[See Figure 5 for wiring illustration]

A pair of standard RCA jacks supplies a conventional unbalanced analog output signal from the RCC-955 to the source inputs of an audio preamplifier, integrated amplifier, or receiver. RCA connections are found on virtually all components. Select high quality audio interconnect cables. Connect the left channel output of the RCC-955 to the left channel source input on the preamplifier or other component. Connect the right output of the RCC-955 to the right channel source input on the preamplifier or other component.

Digital Output 15

[See Figure 6 for connection illustration]

If you are using the RCC-955 as a disc transport with an outboard D/A converter or other digital processor, you need an unprocessed digital data stream from the RCC-955, taken before the built-in D/A converter. This signal is supplied by the back-panel coaxial digital output jack. Using a standard 75 ohm coax cable, connect the digital output jack to the digital input connector on the outboard D/A converter.

Remote Control

The RCC-955 is supplied with an RR-D92 remote control. When using the RR-D92 the emitter on the front of the control must be pointed at the RCC-955 front panel. The basic disc play functions are controlled by the button located near the front of the RR-D92. There is a cover over the lower portion of the RR-D92 that slides down to reveal buttons that control secondary functions, such as programming, disc scanning and direct disc selection.

The RR-D92 duplicates the basic disc play control functions of the front panel control buttons. When a disc play control is on both the front panel and the remote control, both control identifiers are shown in the related instruction text. For example, to play a disc you can press either 7 on the front panel or 19 on the remote control. There are some functions, such as programmed track play functions, that are operated exclusively by the RR-D92.

Remote Sensor 3

The Remote Sensor picks up the infrared signals from the remote control. Do not cover or block the sensor. It must be unobstructed or the remote control will not work properly. The operation of the Remote Sensor can also be affected if it is exposed to bright light, particularly sunlight. Certain types of lighting, such as halogen lights, that emit a fair amount of infrared light, can also interfere with proper operation. In addition remote control functions may not work reliably if the batteries in the RR-D92 are weak.

External Remote Input 14

This connector is designed to be used in conjunction with Xantech™ brand Video Link™ IR signal pick ups (sold separately by custom system installers). This feature enables you to operate the RCC-955 with the hand held remote control even when it is installed where is not visible from your listening location. Contact your authorized Rotel dealer for more information.

Video Link and Xantech are Trademarks of Xantech Corporation.

Remote Control Batteries

The supplied batteries must be installed before the remote control can be used. Slide the secondary control cover down until it stops. Then gently press the small triangular symbol on the cover and slide the cover down to expose the battery well. Install the batteries with the terminals as shown in the illustration in the battery well. Test the control for proper operation, then slide the cover back into place. When the batteries become weak the remote control won't operate the RCC-955 consistently. Installing fresh batteries should eliminate the problem.

Note: Remove the batteries from the remote control if it will not be used for a long period of time. Do not leave run down batteries in the remote control. Exhausted batteries can leak corrosive chemicals which will damage the unit.

Loading Discs

Disc Tray 5 and Open/Close Buttons 6 and 17

Press the Open/Close button on either the front panel or the remote control to open the Disc Tray. Place discs in the numbered recesses in the Disc Carousel with the label sides up. Be sure the discs are centered in the recesses in the Disc Carousel. Both standard 12cm disc and 8 cm disc may be loaded. There is a separate recessed area in the carousel for 8cm discs. When the Disc Tray is open discs can be loaded into the three disc positions at the front of the tray. To load discs into the remaining positions press the Disc Skip button 11 to rotate the carousel. Press the Open/Close button again to close the Disc Tray when you are done loading discs.

Note: Do not push the Disc Tray in manually. Doing so could cause damage. Use the Open/Close buttons. Do not touch the Disc Carousel while it is turning or attempt to turn it by hand, as this also could cause damage. Use the Disc Skip buttons and let the Disc Carousel come to a stop before loading or removing discs.

You can also load discs into the RCC-955 while a disc is playing. Press the Open/Close button to open the Disc Tray. Three of the four disc positions will be available for disc loading. To access the remaining position press the Disc Skip button. The disc tray will turn to allow access to the remaining disc position. Press the Open/Close button again to close the Disc Tray when you are done loading discs.

Disc Skip Buttons 11 and 22

The Disc Skip buttons have two functions. One is to turn the Disc Carousel when you are loading discs, as described in the previous section.

Note: Do not turn the carousel by hand; use the Disc Skip button. Do not touch the carousel while it is turning.

The other function of the Disc Skip button is to select a disc to be played. The next higher numbered disc is selected each time the Disc Skip button is pressed. If disc 5 is selected, pressing the Disc Skip button selects disc 1.

Pressing the Disc Skip button when a disc is not playing selects the next disc. If the Disc Skip button is pressed when a disc is playing, the RCC-955 stops playing the current disc, selects the next disc, and begins playing track 1 of that disc.

Selecting a Disc to Play

In addition to the Disc buttons described above, the remote control may also be used to select discs.

Disc 1-5 Buttons 25 (remote only)

Press the button that corresponds to the disc you want to select. Pressing one of the Disc 1-5 buttons when a disc is not playing simply selects the corresponding disc. If one of the Disc 1-5 button is pressed when a disc is playing, the RCC-955 stops playing the current disc, selects the corresponding disc, and begins playing track 1 of the disc.

Playing Discs

Play Buttons 7 and 19

Press the Play Button to play the disc indicated in the Disc Display. The disc will begin playing with Track 1, unless another track has been selected before the Play button is pressed.

Unless one of the Repeat Play functions has been selected:

- After the last track on discs 1 through 4 is played, the next disc is selected and play continues with track 1 of the disc.
- At the end of disc 5 disc play stops.

See the Repeat Play section for more information.

Pause Button 9 20

Press the Pause Button to temporarily stop playing the disc. Press the Pause Button again, or the Play Button, to resume playing the disc at the same track and time.

Stop Button 8 24

Press the Stop Button to stop playing the disc. The disc will remain selected but the track selection will go back to track 1.

Track Skip Buttons 10 18

When a disc is not playing:

- Press the ►► button to select the next track on the disc. Press and hold the ►► button to advance more than one track on the disc.
- Press the ◀◀ button to select the previous track on the disc. Press and hold the ◀◀ button to go back more than one track on the disc.

When a disc is playing:

- Press the ►► button to skip the rest of track being played and begin playing at the beginning of the next track on the disc. Press and hold the ►► button to advance more than one track on the disc.
- Press the ◀◀ button to return to the beginning of the track being played. Press and hold the ◀◀ button to go back more than one track on the disc.

Track Selection Buttons 26 (remote only)

To select a specific track on a disc, press the corresponding Track Selection buttons. The selected track immediately begins playing. To select tracks higher than number 10 use the ">10" button. For example, to select track 17, press the ">10" button then the "7" button. **Note:** When the RCC-955 is in Programmed Play mode, the Track Selection buttons are used to select tracks to be added to the program. See the Programmed Disc Play section.

Search Buttons 21 (remote only)

Press and hold the ►► or ◀◀ buttons to quickly search a disc in the forward or reverse direction. For the first five seconds the search speed will be approximately four times normal playing speed. After three seconds the search speed will increase to approximately 20 times normal playing speed. The sound volume is reduced while the search function is being used. The search function may be used when disc play has been temporarily stopped with the Pause function, however no sound is heard. The Search function will not go past the beginning or end of the selected disc.

Display Panel 4

The Disc Indicators **A** shows the positions in the Disc Tray that have discs in them.

The Play Indicator **B** is lit whenever a disc is playing.

The Pause Indicator **C** is lit when disc play has been temporarily stopped with the Pause button.

The Disc Selection Indicator **D** typically shows the number of the disc currently selected. If the Remaining Disc Playing Time display option has been selected the Disc Selection Indicator changes to a "-". See the Time Display section.

The Track Indicator **E** shows either the track that is selected, the total number of tracks on the disc, or the number of tracks that remain on the disc. See the Time Button section.

One of the Repeat Play Mode Indicators **F** will light if one of the repeat play options has been selected. See the Repeat Play Button section for more information.

The Random Play Indicator **G** is lit when one of the random play options is being used. See the Random Play section.

The Program Play Indicator **H** lights whenever the track programming function is activated. See the Programmed Play Section.

The Intro Scan Indicator **I** is lit when the Intro Scan feature is activated. See the Intro Scan section.

The Remaining Time Indicator **J** lights when one of the alternative time display functions is activated. See the Time Display Section.

The Time Display **K** shows either the total playing time of the disc that is selected, the amount of time the current track has been playing, the remaining playing time of the current track, or the remaining time of the disc that is playing. See the Time Button section.

Track Calendar Display **L** shows the total number of tracks on the disc that is playing and the track that is currently playing. If the selected disc has more than 16 tracks the Additional Track Indicator **M** is lit.

When a disc is selected, the Track Calendar Display shows the total number of tracks on the disc. The number of the track that is playing flashes. After a track is played the number for that track is turned off. If there are more than 16 tracks on the disc after track 16 is played the **M** indicator flashes. The Track Indicator shows number of the track being played, or the number of tracks remaining, depending on the Time Display mode selected.

When programmed tracks are played, only the number(s) of the programmed track(s) are illuminated. The number of the track that is playing flashes, and is turned off after the track is played. See the Programmed Play section.

Time Display Button 23 (remote only)

When a disc is selected, but not playing, the Time Display shows the total playing time of the disc and the number of tracks on the disc. When a disc is playing, the Time Display shows the track number and the amount of time the track has been playing. Press the Time Display button to change the Time/Track Display mode.

Each/Remain Mode

Press the Time button once to select the Each/Remain mode. The Remaining Time Indicator lights. The Track Indicator shows the track being played. The Time Display shows the amount of time remaining on the track that is playing.

Total/Remain Mode

Press the Time button again to select the Total/Remain mode. The Remaining Time Indicator remains lit. The Track Indicator shows the number of tracks remaining to be played. The Disc Display changes from the number of the disc that is playing to a “-”. The Time Display shows the amount of time remaining on the disc.

Pressing the Time button when the Total/Remain mode is selected changes the Time/Track Display back to the Normal Display mode. The Time/Track Display also reverts to the normal display mode when disc play is stopped and started again.

Repeat Play Button 27 (remote only)

Normally discs 1 through 5 play in sequence and play stops at the end of disc 5. Press the Repeat Play button to select the Repeat 1 Track mode. Press it again to select the Repeat 1 Disc mode. Press it again to select the Repeat All Disc mode. Press it once more to return to normal disc play mode. Repeat Play functions may be turned on or off at any time, even when a disc is playing.

Repeat 1 Track

When the Repeat 1 Track function is selected the “Repeat” and “1” indicators in the display light. If the Repeat 1 Track option is selected when a disc is not playing, the track that is selected when the play button is pressed is repeated. If the Repeat 1 Track option is selected while a track is playing, that track continues to play and is then repeated.

The Track Skip buttons function normally when the Repeat 1 Track option is selected. If a new track is selected with the Track Skip buttons, it is repeated until the Repeat Playing option is turned off. The Search buttons function normally when the Repeat 1 Track option is selected. You can search forward to the next track, and backward to the previous track. The new track is then repeated.

If the Programed Play feature is being used the Repeat 1 Track feature cannot be selected.

Repeat 1 Disc

When the Repeat 1 Disc function is selected the “Repeat”, “1” and “Disc” indicators in the display light. If the Repeat 1 Disc option is selected when a disc is not playing, the disc that is selected when the play button is pressed begins playing track 1. After the last track on the disc, play continues, starting with track 1 of the disc. If the Repeat 1 Disc option is selected while a track is playing, that track continues to play. After the last track on the disc, play continues, starting with track 1 of the disc.

The Track Skip buttons function normally when the Repeat 1 Track option is selected. If a new track is selected with the Track Skip buttons, it is repeated until the Repeat Playing option is turned off. The Search buttons function normally when the Repeat 1 Track option is selected. You can search forward to the next track, and backward to the previous track. The new track is then repeated.

If the Programed Play feature is being used the Repeat 1 Track feature cannot be selected.

Repeat All Discs

When the Repeat All Discs option is selected the “Repeat All Disc” indicators in the display are lit. All the tracks on all the discs are played in sequence, beginning with the track that is selected or playing. After the last track on disc 5 is played, track 1 of disc 1 is played. All the discs continue to play in sequence until the Repeat All Discs function is turned off.

The Disc Skip and Disc Search feature work normally when the Repeat All Discs function is turned on.

If the Programed Play feature is being used, the programmed tracks are played in sequence. When the last programmed track is played, play continues with the first programmed track. See the Programed Play section for more information.

The Track Skip and Search functions work normally when the Repeat All Discs feature is being used.

Random Play Button 28 (remote only)

The Random Play feature randomly selects tracks to be played. Press the Random button to turn the feature on. Press it again to turn Random Play off. When the Random Play is active the Random Indicator **G** in the display is illuminated.

If Random Play is turned on when a disc is not playing, a track is randomly selected when the play button is pushed. If a disc is playing when Random Play is turned on, another track is randomly selected immediately and begins playing.

The Random Play feature can be set to select only tracks from a single disc. While a disc is not playing, press the Random Play button 29, then select the number of the disc to select tracks from with the disc select buttons 25. When you press the play button tracks are randomly selected from the selected disc.

If the Track Skip Forward button **▶▶** is pressed when a disc is playing and Random Play is turned on, another track is immediately randomly selected. If the Track Skip Back button **◀◀** is pressed when a disc is playing and Random Play is turned on, the same track begins playing from the beginning.

The Search Forward button **▶▶** functions normally when Random Play is turned on. If you search forward to the end of a track another track is randomly selected. The Search Reverse button **◀◀** will allow you to search back to the beginning of the track that is playing.

Random Play can be used in conjunction with Programmed Play. If Random Play is turned on after a set of tracks has been programmed, the programmed tracks are played in random order. Note: In order to use these two together the Random Play must be turned on after tracks have been programmed. If Random Play is turned on the Programmed Play feature cannot be selected.

If the Repeat 1 Track or Repeat 1 Disc feature is on, it is deactivated when Random Play is turned on. The Random Play and Repeat All Discs features may be used together.

The Intro Scan feature is interactive with Random Play, Programmed Play and Repeat Play. Such combined functions will rarely be used. For example, if both Intro Scan and Repeat Play/All are turned on, the first ten seconds of each disc is played continually in sequence. If both Intro Scan and Random Play are turned on, the first ten seconds of randomly selected tracks are played. If Intro Scan and Programmed Play are active, the first ten seconds of each programmed track are played in sequence. If Repeat Play/All is also active the first ten seconds of each programmed track are played in sequence continually. Other combinations of functions are possible, but again are unlikely to be used.



Programmed Disc Play

Up to 32 tracks, on any of the loaded discs, can be in selected for playback. After a group of tracks have been programmed, they are played back in the programmed order. All programming and programmed play functions are done with the remote control.

Program Button **30**

The Program Button is used to turn the Programmed Play feature on and off. When Programmed Play is turned on the Program Play Indicator **H** in the display is lit.

Once a group of tracks have been programmed, only those tracks may be played until the Programmed Play feature is turned off. Press the Program Button to turn off Programmed Play, clear the programmed tracks and return to normal play mode. Programmed tracks are also cleared when the Disc Tray is opened and when the power is turned off.

Track Programming

Programming While a Disc is Playing

Press the Program Play button **30**, the Program Indicator **H** in the display lights. The track that is playing when the Program Button is pressed becomes the first programmed selection. The Time display **K** briefly displays "P-01" indicating the track is now programmed selection 1. If the second track you want to add to the program list is on the same disc, use the Track Selection buttons **26** to select the next track. If the second track you want to add to the program list is on a different disc, use the Disc Selection buttons **25** to select the next disc. The Track and Time displays change to indicate another selection is being made. The Time display **K** briefly displays "P-02" indicating the track is now programmed selection 2. Continue selecting new discs (if necessary) and tracks until you have programmed all the tracks you want. Then press the Play button to begin playing the programmed tracks.

Intro Scan Button **29** (remote only)

The Intro Scan feature lets you listen to a short section of the beginning of musical tracks. Press the Scan button to turn on the Intro Scan feature. Press the Scan button again, or the Stop button, to turn Intro Scan off. When the Intro Scan feature is active the Intro indicator **I** in the display is lit.

If Programmed Play is not being used, the first 10 seconds of each track on each loaded disc is played in sequence, beginning with the currently selected track. After the first 10 seconds of the last track on disc 5 is played, Intro Scan playing stops. If Programmed Play is being used, the first 10 seconds of each programmed track is played, beginning with the currently selected programmed track. After the first 10 seconds of the last programmed track is played, Intro Scan playing stops.

If Intro Scan is turned on when a disc is not playing, scanning begins with the track that is selected. If a disc is playing when Intro Scan is turned on, the RCC-955 skips to the next track, plays the first 10 seconds of that track, and each of the following tracks. There is one exception - if Intro Scan is turned while the first 10 seconds of a track is playing. In that instance the remainder of the first 10 seconds of that track is played. The RCC-955 then skips to the beginning of the next track and continues scanning.

Programming Example

While Disc 4 / Track 7 is playing . . .

Press	Action
Program Button	Disc 4 / Track 7 becomes selection 1
Track Button 3	Disc 4 / Track 3 becomes selection 2
Disc Button 2, then Track Button 6	Disc 2 / Track 6 becomes selection 3
Track buttons >10 then 1	Disc 2 / Track 11 becomes selection 4
Disc Button 5, then Track Button 9	Disc 5 / Track 9 becomes selection 5
Track Button 7	Disc 5 / Track 7 becomes selection 6
Track Button 4	Disc 5 / Track 4 becomes selection 7
Disc Button 1, then Track Buttons >10 then 2	Disc 1 / Track 12 becomes selection 8
Track Button 10	Disc 1 / Track 10 becomes selection 9

Programming While a Disc is Not Playing

Press the Program Play button **30**, the Program Indicator **H** in the display will light. If the track you want to select first is on the disc that is already selected simply press the Track Selection button(s) **26** to select the first track. The Time display **K** will briefly change to display "P-01" indicating the track is now programmed selection 1. If the track you want to program first is on a different disc from one selected use the Disc Selection buttons **25** to select a different disc, then select the track with the Track Selection buttons. If the second track you want to add to the program list is on the same disc simply use the Track Selection buttons to select the next track. If the second track you want to add to the program list is on a different disc use the Disc Selection buttons to select the next disc. The Track and Time displays will change to indicate another selection is being made. The Time display will briefly change to display "P-02" indicating the track is now programmed selection 2. Continue selecting new discs (if necessary) and tracks until you have programmed all the tracks you want.

Programming Example

While disc 3 is selected but not playing . . .

Press	Action
Program Button	Program Mode is activated
Track Button 3	Disc 3 / Track 3 becomes selection 1
Track Button 7	Disc 3 / Track 7 becomes selection 2
Disc Button 4, then Track Buttons >10 then 4	Disc 4 / Track 14 becomes selection 3
Disc Button 5, then Track Button 9	Disc 5 / Track 9 becomes selection 4
Track buttons >10 then 2	Disc 5 / Track 12 becomes selection 5
Disc Button 1, then Track Button 8	Disc 1 / Track 8 becomes selection 6
Disc Button 2, then Track Button 4	Disc 2 / Track 4 becomes selection 7
Track Button 1	Disc 2 / Track 1 becomes selection 8

Adding Tracks to a Program

You can add track selections to the programmed list at any time, even after you've begun playing programmed selections. If the track you want to add is on the disc that is playing, just select the new track with the Track Selection buttons. Or use the Disc Selection buttons and the Track Selection buttons to program new tracks to add tracks from another disc to the program.

Review Button **31**

Press the Review button to review the programmed tracks. Each time the button is pressed the next disc/track selection, and the program position number, is displayed. This function can be used at any time – when programming, while playing programmed tracks or while programmed tracks are not playing. If you review the programmed tracks while programming or playing programmed tracks, the display temporarily changes to show the programmed selections and then returns to normal mode.

Playing Programmed Tracks

Once a group of tracks has been programmed press the Play button to begin playing the tracks, starting with programmed selection 1. The selected tracks will play in sequence until the last selected track is over. Then disc play stops.

When programmed tracks are playing, the Track Calendar **L** in the display shows only the numbers of the programmed tracks. The number of the track that is playing flashes.

The Pause button functions normally when playing programmed tracks. If you press the stop button while playing programmed tracks, play resumes with programmed selection 1 when the play button is pressed again.

The Track Skip buttons function normally when playing programmed tracks. Press the **▶▶** button to skip to the next programmed track. Press the **◀◀** button to return to the beginning of the track that is playing. Press the **◀◀** again to go back to the previous programmed track. The track skip function will not go past the first or last programmed track unless the Repeat play function is turned on.

The Search Buttons also function when playing programmed tracks. Pressing the **▶▶** button searches forward. If you search to the end of the track the next programmed track is played. If you search to the end of the last programmed track play stops unless the Repeat function is turned on. Pressing the **◀◀** button searches backwards, but the search will not go beyond the beginning of the track that is playing.

The Repeat All Disc function works when programmed tracks are playing. The other Repeat functions cannot be selected. When the Repeat function is turned on the first programmed track begins playing after the last programmed track has been played. Similarly, the first programmed track begins playing if you press the **▶▶** when the last programmed track is playing or if you press the **▶▶** until you reach the end of the last programmed track.

Troubleshooting

Most difficulties in audio systems are the result of incorrect connections, or improper control settings. If you encounter problems, isolate the area of the difficulty, check the control settings, determine the cause of the fault and make the necessary changes. If you experience problems with the RCC-955, refer to the suggestions for the following conditions:

Display Is Not Lit

The Disc, Track and Time indicators in the display should be lit whenever the power switch of the RCC-955 is pushed in. If the display does not light, test the power outlet with another electrical device, such as a lamp. Be sure the power outlet being used is not controlled by a switch that has been turned off.

Fuse Replacement

If another electrical device works when plugged into the power outlet, but the RCC-955 display will not light when the power switch is pushed in, it indicates that the internal power fuse may have blown. If you believe this has happened, contact your authorized Rotel dealer to get the fuse replaced.

Disc Does Not Play

If a disc does not begin playing when the Play button is pressed, open the disc tray and be sure the disc is loaded with the label side up. If a disc is properly loaded inspect the playing side of the disc for contamination or damage. If the disc is dirty, clean it as described in the Handling Compact Discs section. If a disc is damaged it should be replaced.

No Sound

Check the input selector on the amplifier to be sure it is properly set. Check the tape monitor switches to be sure they are properly set. Check other signal sources to be sure the amplifier is operating properly. Finally check the audio cables between the RCC-955 and the amplifier to be sure they are properly connected.

Sound Skips

If the sound from the RCC-955 skips or jumps around, the disc may be defective or dirty. If the disc is clean, try another disc. If a problem persists it could be caused by vibrations reaching the RCC-955. Sound vibrations, especially from a subwoofer, can interfere with the laser reading a disc surface. Move the RCC-955 to a more stable surface, or to a location farther away from the speakers.

Hum

Hum is caused by electrical interference from other devices. It is most often picked up by the audio signal cables. Use high-quality cables. Low quality cables often have inadequate shielding. Check to be sure the cables are solidly connected to both the RCC-955 and the amplifier. Try moving the cables to a position farther away from other electrical components, especially power amplifiers which have large power transformers. Other devices that commonly cause interference are fluorescent lights and light dimmer controls.

Specifications

Frequency Response (+0.5dB, -3.0dB)	20-20,000 Hz
Signal to Noise Ratio	96 dB
Dynamic Range	93 dB
Channel Separation	90 dB @ 1kHz
Total Harmonic Distortion + Noise	0.008% @ 1kHz
Maximum Audio Line Output	2 Volts
Digital Output Level (coax)	0.5 Volt, Peak to Peak
Digital Output Impedance	75 Ohms
Power Requirements	
USA Version	115 Volts, 60 Hz;
European Version	230 Volts, 50 Hz
Power Consumption	15 Watts
Dimensions (W x H x D)	440 x 125 x 395 mm
	17 ⁵ / ₁₆ x 4 ¹⁵ / ₁₆ x 15 ¹ / ₂ inches
Weight (net)	5.7 kg, 12.6 lb.

All specifications are accurate at the time of printing.
Rotel reserves the right to make improvements without notice.

RCC-955

CD MULTI-DISC CHANGER

The Rotel Co. Ltd.

10-10 Shinsen-Cho
Shibuya-Ku
Tokyo 150-0045
Japan

Phone: +81-3-5458-5325
Fax: +81-3-5458-5310

Rotel of America

54 Concord Street
North Reading, MA 01864-2699
USA

Phone: +1 978-664-3820
Fax: +1 978-664-4109

Rotel Europe

Meadow Road
Worthing, West Sussex BN11 2RX
England

Phone: +44 1903-524-813
Fax: +44 1903-524-831

Rotel Deutschland

Kleine Heide 12
D-33790 Halle/Westf.
Germany

Phone: +49 5201-87170
Fax: +49 5201-73370

ROTEL*hiFi*

ROTEL*hiFi*

ROTEL*hiFi*

ROTEL*hiFi*

ROTEL*hiFi*

ROTEL*hiFi*

ROTEL*hiFi*

ROTEL*hiFi*

ROTEL*hiFi*

ROTEL*hiFi*

ROTEL*hiFi*

ROTEL*hiFi*

ROTEL*hiFi*

ROTEL*hiFi*

ROTEL*hiFi*

ROTEL*hiFi*

ROTEL*hiFi*

ROTEL*hiFi*

ROTEL*hiFi*

ROTEL*hiFi*